

The **UCL Environment Institute**:

the focal point for environmental research at UCL

The **UCL EI *Water* theme**, across the Departments of:

Biology

Civil, Environmental & Geomatic Engineering

Earth Sciences

Geography

Statistics

# Water Resources Management - UCL

- rainfall simulation, recharge
- groundwater resources, aquifer characterisation
- threats to groundwater resources
- impacts of development
- water quality management
- optimization, and public perception

# Water Resources Management - UCL

## Rainfall simulation, recharge: *Chandler, Isham, Taylor*

Weather & climate forecasting,  
simulation and downscaling



Key to gauge symbols

- Used for fitting only
- ▲ 3-gauge average
- Other sites in simulations

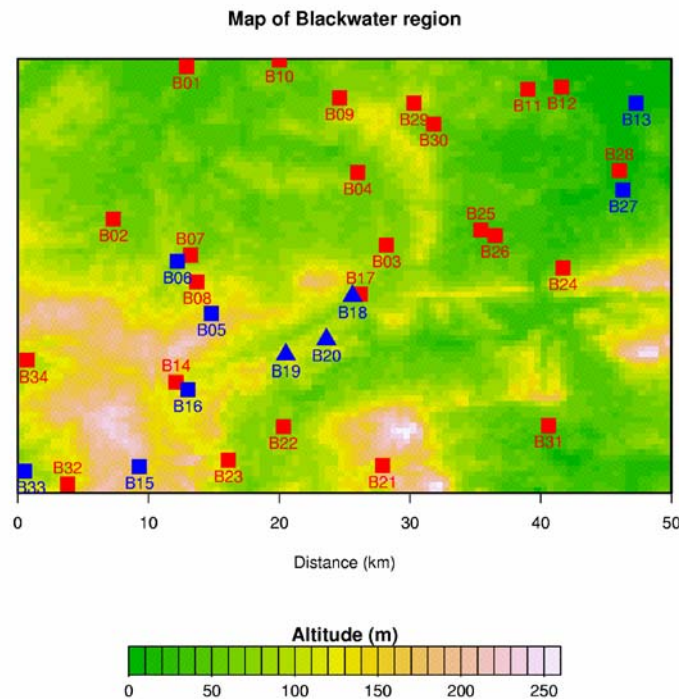

## Rainfall and recharge distribution in equatorial Africa

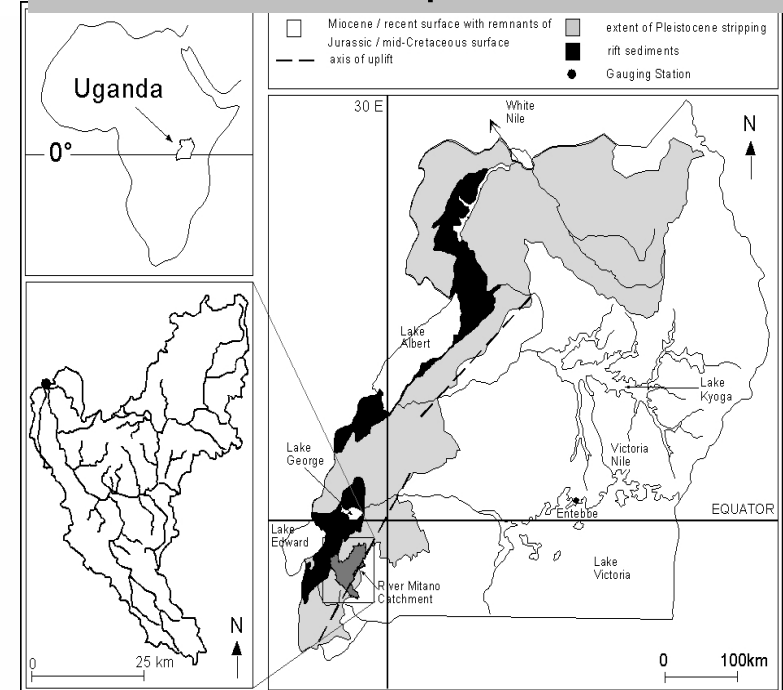

# Water Resources Management - UCL

## Groundwater resources, aquifer characterisation *Atkinson, Burgess, Taylor*

Lithological basis for hydrostratigraphy of deep aquifers, southern Bangladesh

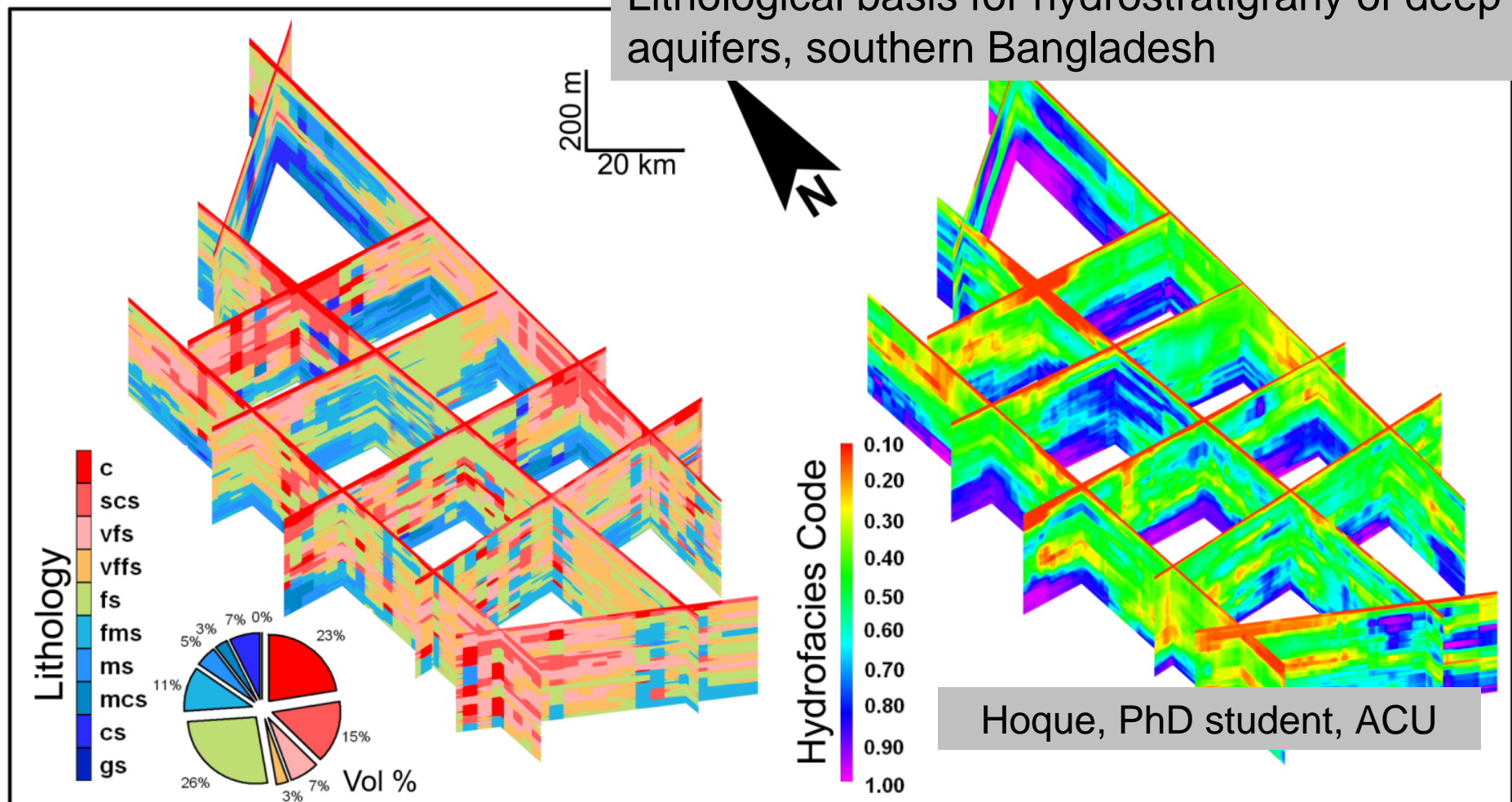

# Water Resources Management - UCL

## Threats to groundwater: contaminants *Atkinson, Burgess, Taylor*

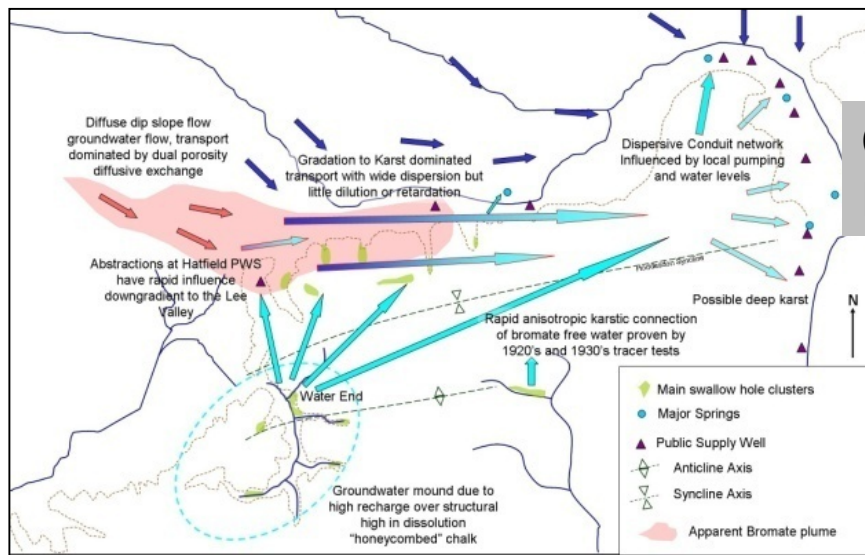

Cook & Fitzpatrick, EngD students,  
EPSRC + 3VW + THUL

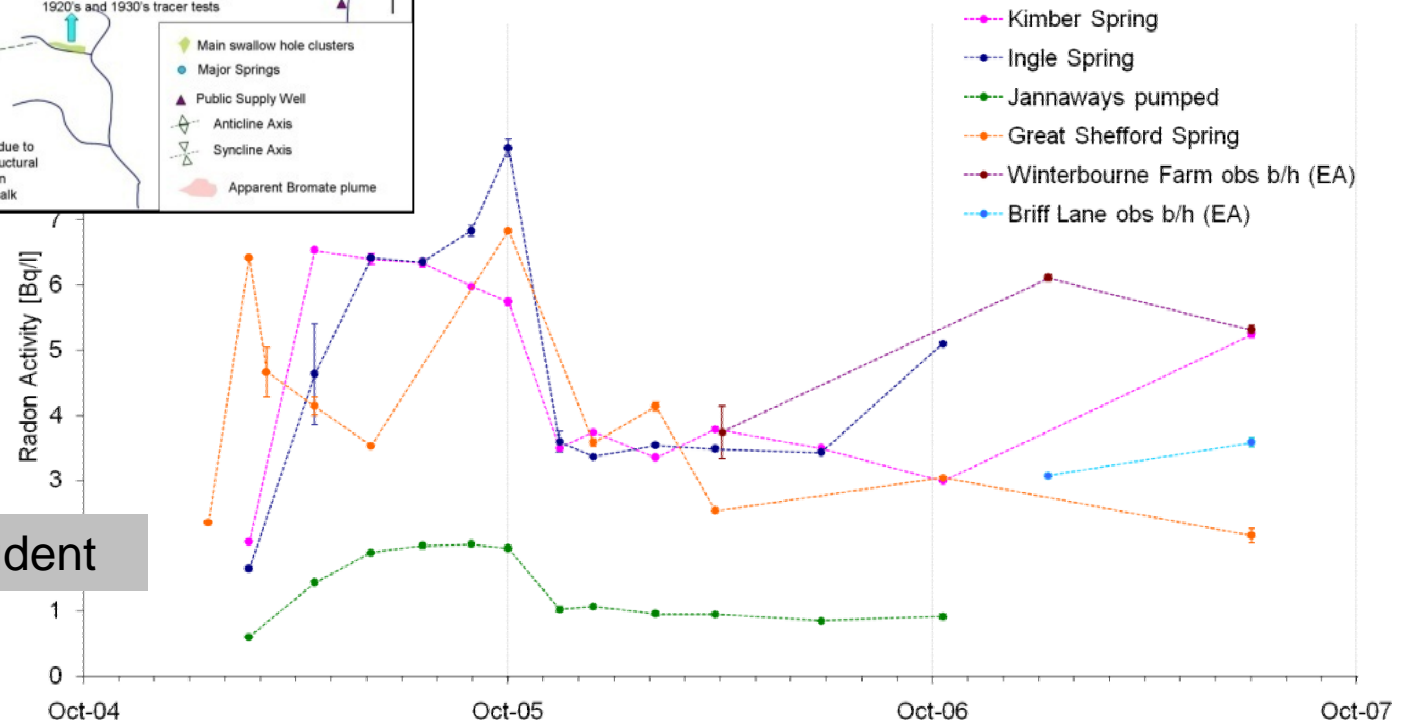

Quinn, PhD student

# Water Resources Management - UCL

Threats to groundwater: contaminants

*Atkinson, Burgess, McArthur, Taylor*

James, EngD student, EPSRC + NHM: Mineralogical sources of fluoride and trends of F in groundwater, rural India



# Water Resources Management - UCL

## Threats to groundwater: climate *Chandler, Taylor, Todd*

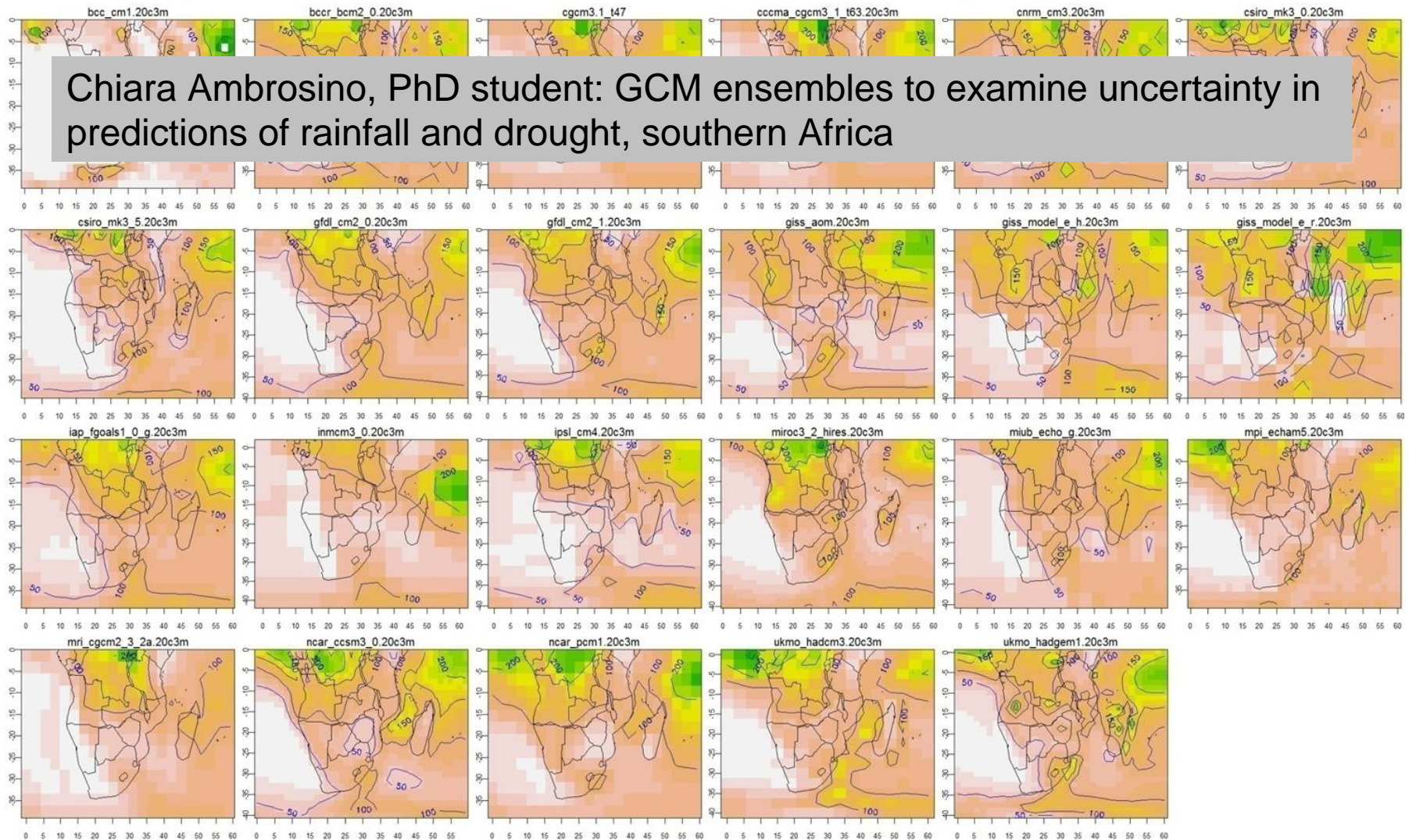

# NERC QUEST-GSI: *Global-scale impacts of climate change*

## QUEST-GSI (consortium) aim:

- To quantify the implications of different rates and degrees of climate change for a wide range of ecosystem services across the global domain

## UCL aim:

- To quantify the impact of (defined) climate and development scenarios and potential adaptation on freshwater resources at the catchment scale in Africa and China

simulate runoff under specified climate scenarios

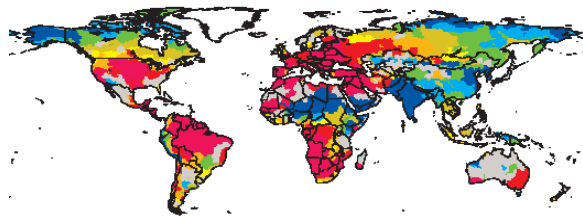

repeat with multiple scenarios to construct  
*Climate Impact Response Function*

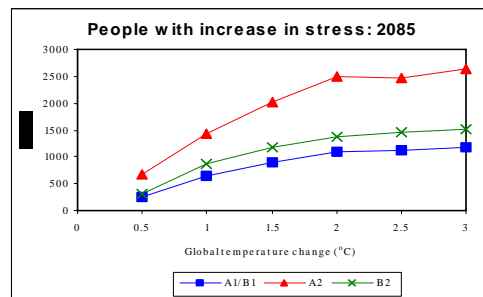

calculate indicator of impact under specific climate / land cover / socio-economic scenarios

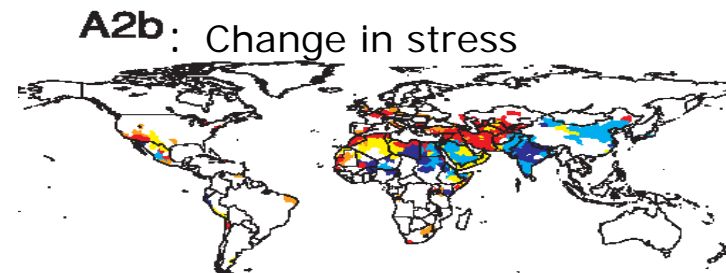

# Water Resources Management - UCL

Impacts: *ECRC - Holmes, Benion et al*  
(6 academic, 20 research staff)

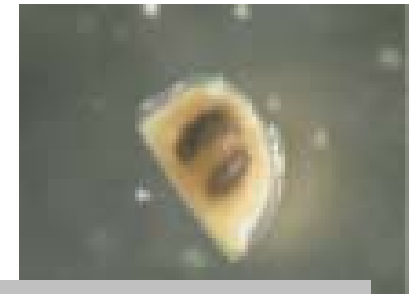

Palaeoecology in the management & restoration of freshwaters



# Water Resources Management - UCL

## Water quality management *Khraisheh, Stegemann*

Modelling the recovery of sediments containing PCBs

Jason Go (PhD student, NERC/BP)

Also, adsorption and biosorption processes in water treatment

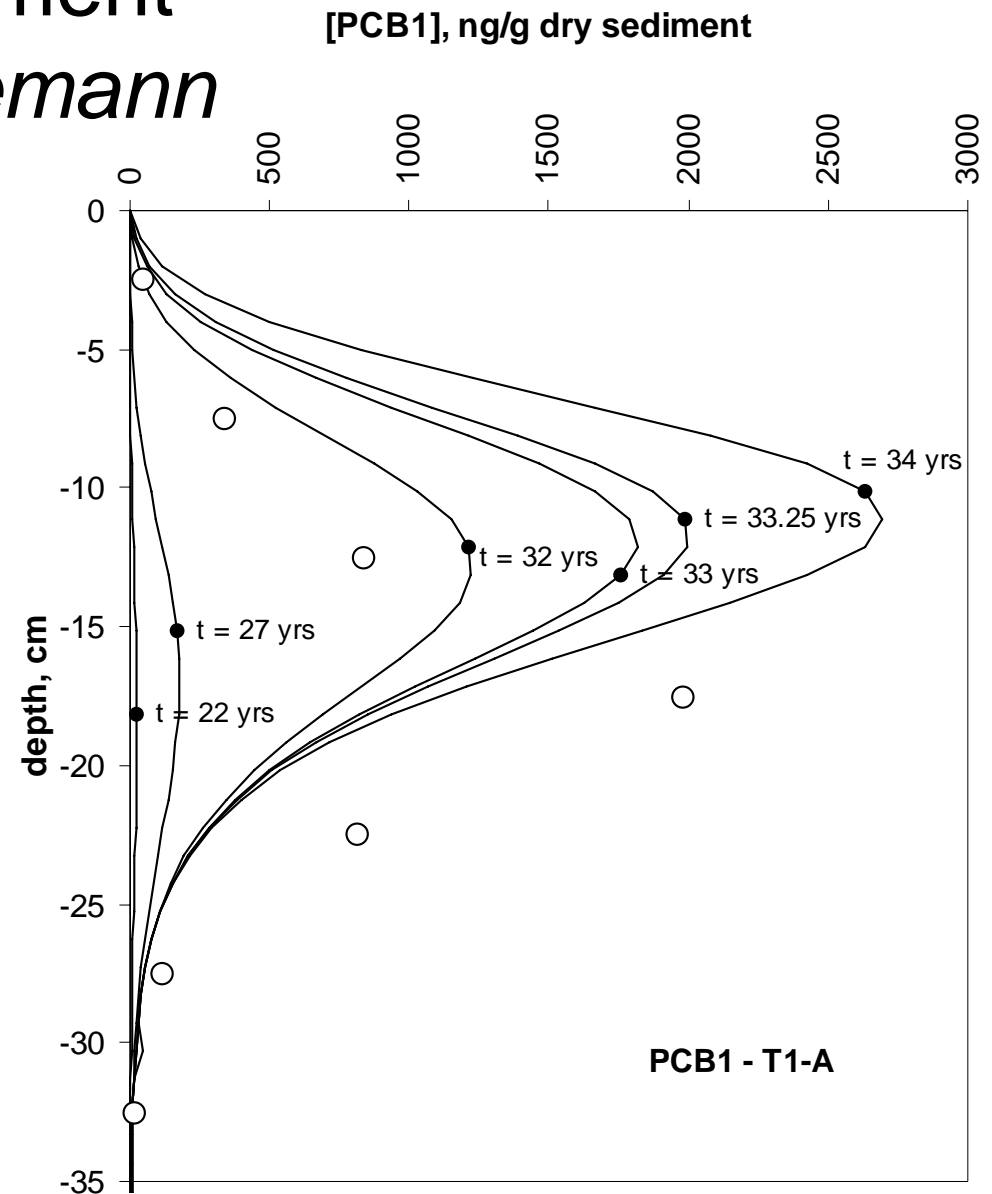

# Water Resources Management - UCL

## Optimization, & public perception *Harou, Bell*

Julien Harou – Tulare Basin, California

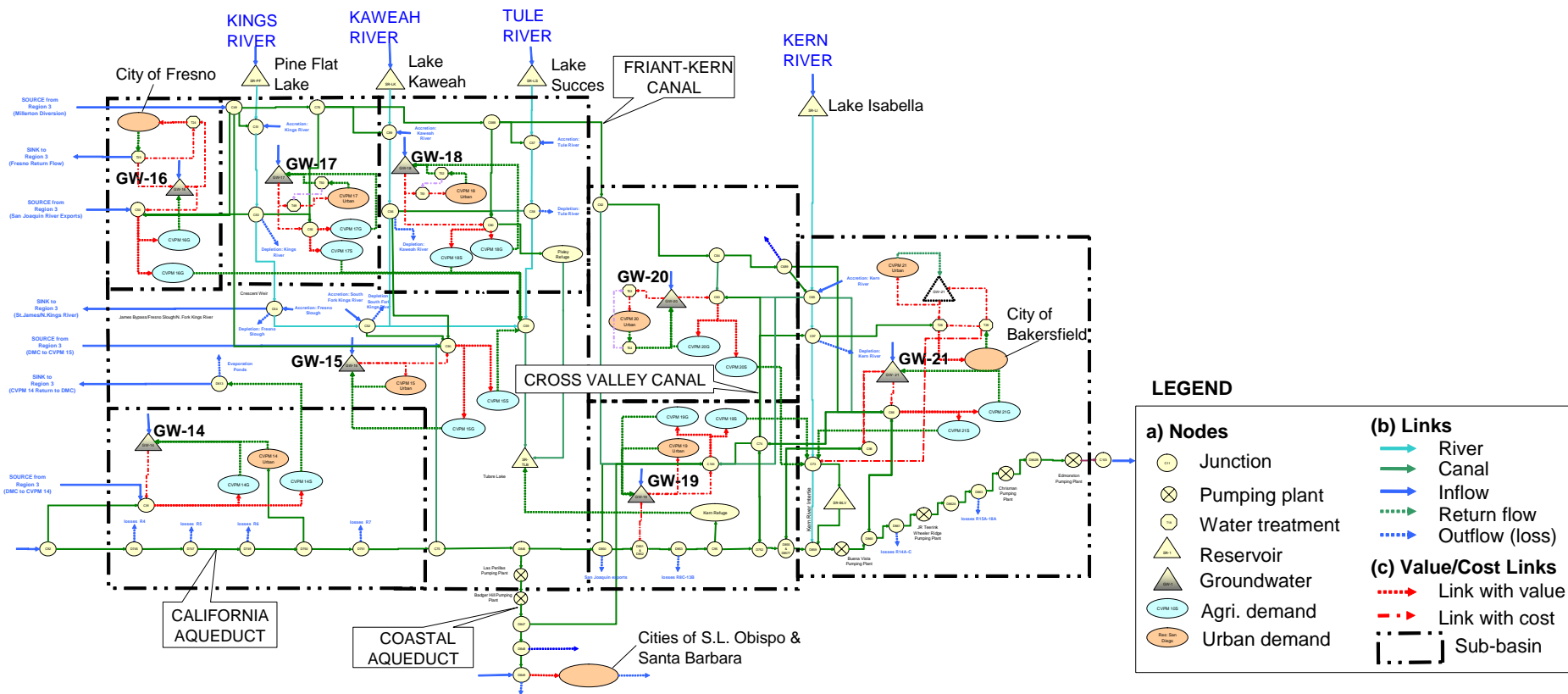

# Water Resources Management - UCL

- rainfall simulation, recharge
- groundwater resources, aquifer characterisation
- threats to groundwater resources
- impacts of development
- water quality management
- optimization, and public perception